

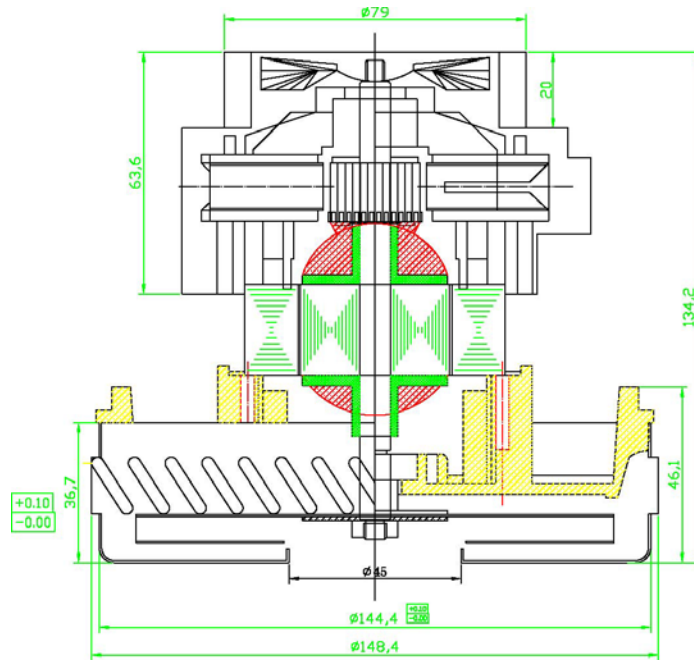

PX-PXT



PX-PXT Technical Parameters

Parameters/ Models	PX-PXT	Tolerance Value
Rated voltage (V)	100-240	/
Rated frequency (Hz)	50/60	/
Rated input power (W)	1000-1400	+10% -10%
Max vacuum degree (KPa)	17-22	-5%
Max air flow (M3/min)	3.0-3.5	-8%
Temperature rise (K)	≤ 75	/
Noise (dB)	≤ 93	/
Spark	<1	/
Class of insulation	E	/
Max efficiency	38%	-10%