

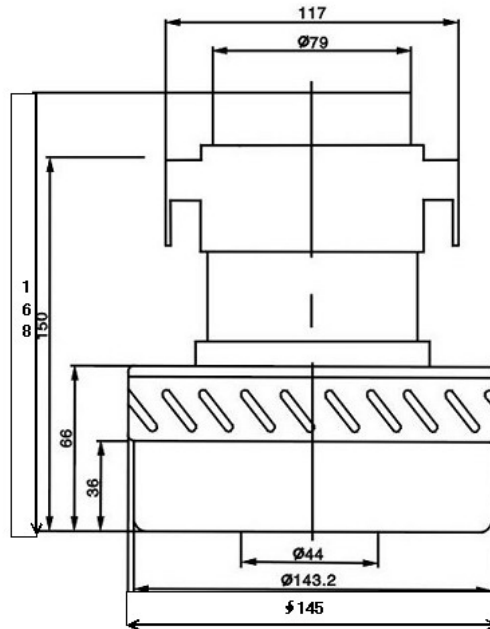

## PX-PR-LG



PX-PR-LG Technical Parameters

| Parameters/Models      | PX-PR-LG  | Tolerance Value |
|------------------------|-----------|-----------------|
| Rated voltage(V)       | 100-240   | /               |
| Rated frequency(Hz)    | 50/60     | /               |
| Rated input power(W)   | 1000-1400 | +10% -10%       |
| Max vacuum degree(KPa) | 24-29     | +5% -5%         |
| Max air flow(M3/min)   | 3.1       | -8%             |
| Temperature rise(K)    | ≦ 60      | /               |
| Noise(dB)              | ≦ 94      | /               |
| Spark                  | <1        | /               |
| Class of insulation    | A、B、E、F   | /               |
| Max efficiency         | ≧33%      | +10%            |